

## Single Photon Counting Module COUNT®-Series

### Description

LASER COMPONENTS' COUNT® series of Single Photon Counting Modules has been developed to offer a unique combination of high photon detection efficiency, wide dynamic range and ease of use for photon counting applications. Combining LASER COMPONENTS' ultra-low-noise VLoK silicon avalanche photodiode with specially developed quenching and signal processing electronics, the module offers everything needed for single photon detection from 400 – 1000 nm. Incoming photons generate corresponding electrical pulses which may be conveniently read out at the TTL output. The gating function allows the module to be disabled between measurements to provide protection against accidental overload. The optional FC connector provides a convenient method for connecting the module to the sample using a multimode optical fiber.



### Features

- Extremely low dark count rates
- Detection efficiency > 70%
- Optional FC fiber connector
- Single 12 V DC supply operation
- Stable count rate (no bi-stability)

### Applications

- Confocal microscopy
- Particle sizing
- Fluorescence analysis
- LIDAR
- Astronomy
- Quantum cryptography

## Technical Specifications for COUNT® Module

Parameter	Min.	Typ.	Max.	Unit
Spectral range	400		1000	nm
Dark count rate				
COUNT-10C			10	Counts/s
COUNT-20C			20	Counts/s
COUNT-50C			50	Counts/s
COUNT-100C			100	Counts/s
COUNT-250C			250	Counts/s
Photon detection efficiency Pd <sup>1</sup> at:				
405 nm	5	15		%
670 nm	60	70		%
810 nm	40	50		%
Pd variation at constant temperature		TBC		%
Active area diameter (nominal) <sup>2</sup>		100		µm
Timing resolution <sup>3</sup>		1000		ps
Afterpulsing probability <sup>4</sup>		0.2	1	%
Dead time	42	45		ns
Gating input voltage				
Gating on (= disable module)		TTL low (<0.5)		V
Gating off (= enable module)		TTL high (>2.4)		V
Gating input response time				
Gating on (= disable module)		15	20	ns
Gating off (= enable module)		60	65	ns
TTL output pulse length		15	17	ns
TTL output pulse amplitude (into 50 Ohm)		3		V
Delay between photon impact and TTL pulse		30		ns
Supply voltage	11.5	12.0	12.5	V
Supply current (switch on)		0.8		A
Supply current (operation at 1 Mcps)		0.2		A

<sup>1</sup> Specifications valid for modules without FC-connector

<sup>2</sup> The active area of the integrated Si-APD is larger than 100 µm.

The FC-version is optimised for optical fibers with core diameter <105 µm. The pre-aligned GRIN lens focuses the light onto a spot of <70 µm diameter in the centre of the detector. Please also see Fig. 2 and 3. The NA of the fiber used with the module is recommended to be ≤ 0.29.

<sup>3</sup> Timing resolution depends on count rate and wavelength.

<sup>4</sup> Defined for a time interval from 0 to 500 ns

### Absolute Maximum Ratings

	Min.	Typ.	Max.	Unit
Supply voltage	11.5	12.0	12.5	V
Operating temperature	10		40	°C
Humidity at 40°C			85	%
Storage temperature	-20		70	°C
Count rate			20	MCOUNTS/s

### Fiber Connection Option

The COUNT®-XX-FC has a FC-style fiber-optic receptacle pre-aligned to the optical detector surface. The GRIN lens used in this assembly is optimized and AR-coated for the range 440 – 1000 nm.

### Heat Dissipation

In order to avoid damage to the module adequate heat sinking must be provided by placing or mounting the module onto a suitable heat sink, e.g. an optical table.

### TTL Output & Power Supply



In order to not damage the APD it is recommended to put ferrite beads or ferrite clamp-ons on all cables leading to the APD. This includes TTL output, gating input and power supply input.

### Optical Fiber Shielding

To avoid stray light impinging on the detector and affecting the count rate, any optical fiber assembly attached to the FC connector must be completely opaque. LASER COMPONENTS offers suitably shielded optical fiber assemblies, please contact us for details.

### Gating Function

The COUNT® module features a gating input provided as standard. This can be used for viewing a signal that occurs only in a small timeframe window, or in applications with very weak signals and higher background. The output of the module is disabled when a TTL low level is applied to the gate input. Applying a TTL high level will enable the module and permit photon detection. If the gate input is left unconnected, the module is enabled by default.



Always switch off the module before connecting or disconnecting the gating input.

## Saturation

The photon count rate rolls off at high incoming light levels. The count rate at which the output starts to decrease is called the saturation point. Precautions should be taken to avoid prolonged exposure excessive light levels that may damage the COUNT® module.

## Warranty

A standard 12-month warranty following shipment applies. Any warranty is null and void if the module case has been opened. Warranty is void if the module input exceeds 12.5 V.

## ESD Information

Modules should only be handled at an ESD-safe work station.

## Individual Module Test Data

Each module is supplied with test data indicating the module's actual dark count, dead time, photon detection efficiency @ 405 nm, 670 nm and 810 nm and afterpulsing probability.

## Safety

The COUNT®-Series contains a high voltage power supply. Users may be injured if the case is opened. All internal settings are pre-set; there are no user adjustments.

Units that appear defective or have suffered mechanical damage should not be used because of possible electrical shorting of the high voltage power supply. Opening the case may damage sensitive components and expose the user to the risk of electrical shock. Please contact factory for repairs.



## RoHS Compliance

The COUNT®-Series is designed and built to be fully compliant with the European Union Directive 2002/95/EC.

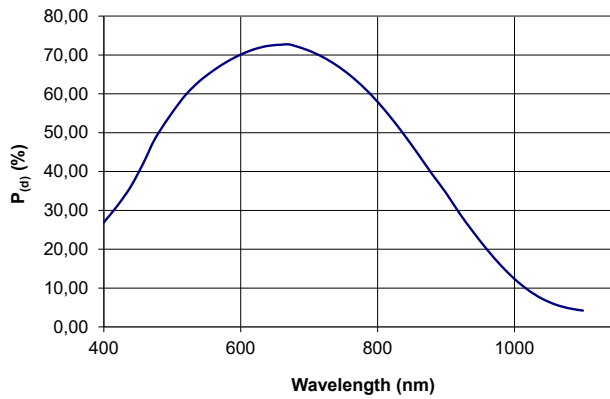

Fig. 1: Typical Photon Detection Efficiency (P<sub>d</sub>) vs. Wavelength

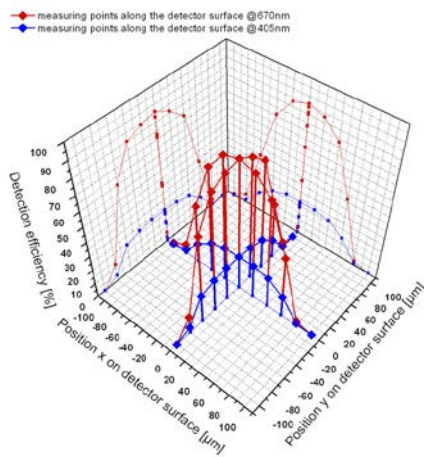

Fig. 2: Typical P<sub>d</sub> scan

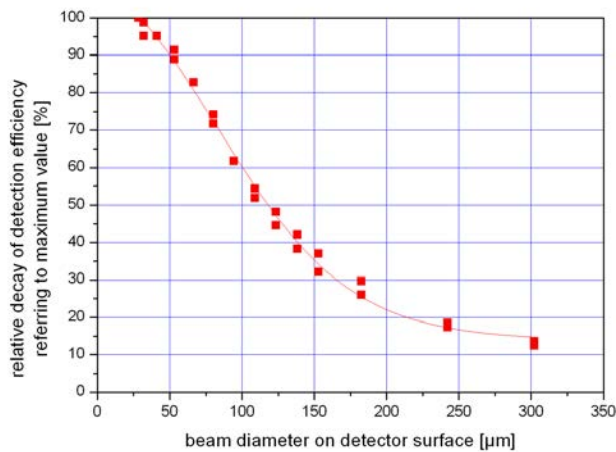

Fig. 3: Beam diameter on detector surface vs. relative intensity of P<sub>d</sub> referring to maximum value

### Correction factor non-linearity

Every COUNT® has an inherent dead time of approximately 43 ns after detecting a photon. During this dead time, the COUNT® is „blind“ and can not detect further photons. As a consequence, the measured counting rate is lower than the true actual counting rate. The true actual counting rate can be calculated from the measured counting rate as follows:

$$R_{\text{actual}} = \frac{R_{\text{measured}}}{1 - R_{\text{measured}} \cdot T_D}$$

where  $R_{\text{actual}}$  = actual counting rate

$R_{\text{measured}}$  = measured counting rate

$T_D$  = SPAD dead time

The dead time effect can also be seen as a deviation from the unity of the ratio between the actual counting rate and the measured counting rate. For the following two figures an exemplary measurement of the linearity of a COUNT-20C with a dead time of 43 ns was performed and compared to the theoretical curve.

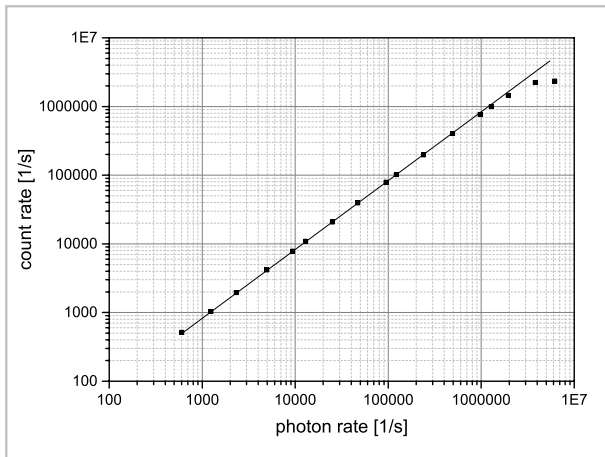

Fig. 4: COUNT rate vs. actual photon rate for a dead time of 43 ns.

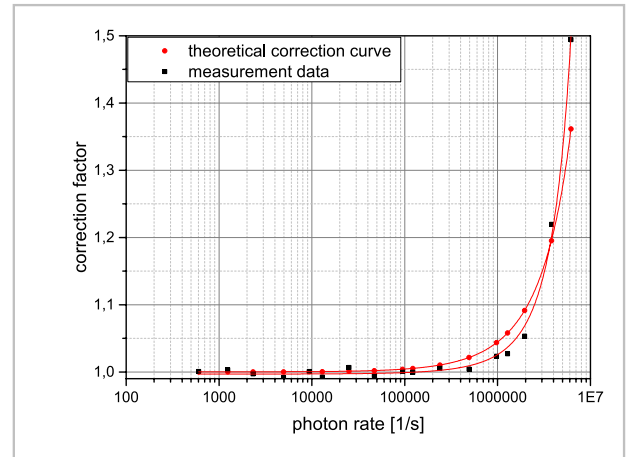
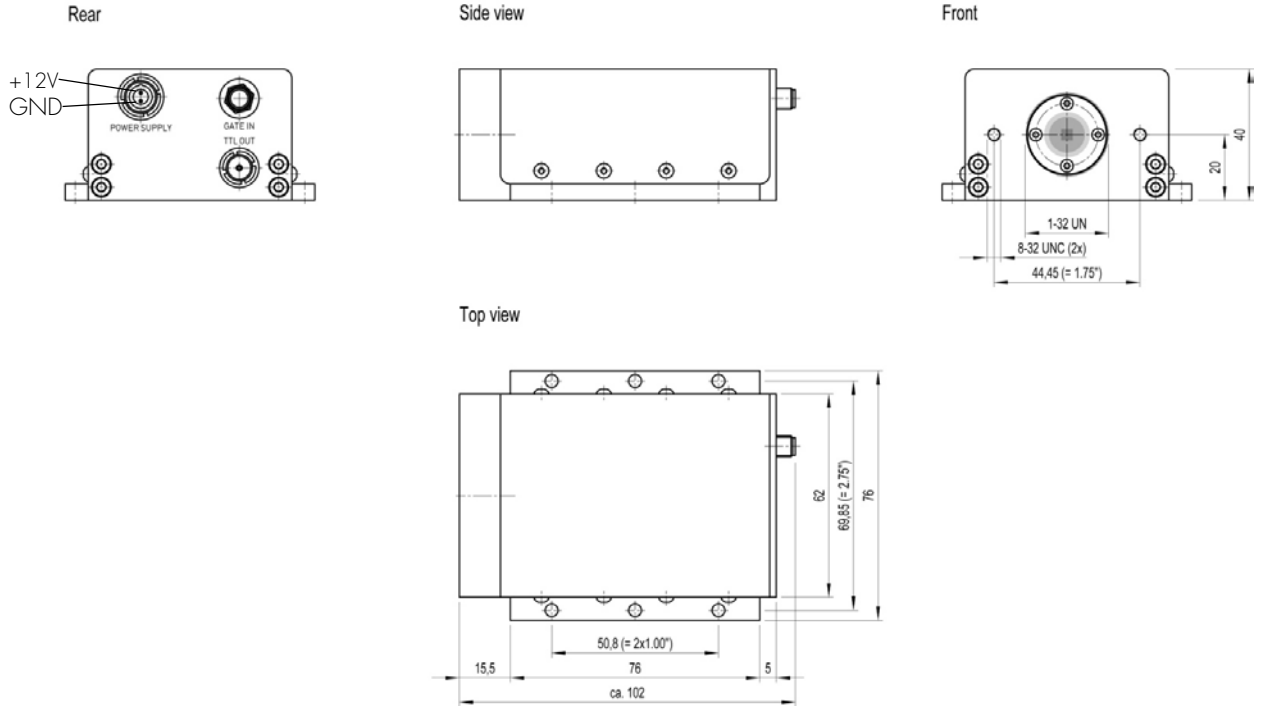

Fig. 5: Correction factor vs. photon rate for a dead time of 43 ns; comparison between theoretical and measured values.

## Package Drawings

### Window Version



Optical distance from top of window to active area plane: typ. 1.35 mm  
Dimensions in mm

### Fiber Connector Version

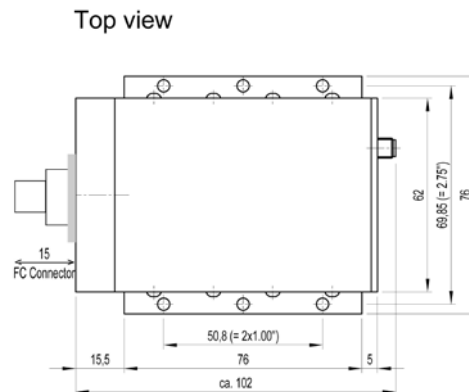

## Interface Information

- Power Supply: LEMO connector, item number FGG.OB.302.CLAD42 (optional COUNT® power supply is available upon request).
- Gate input: SMA connector
- TTL output: LEMO connector, compatible with LEMO/BNC adapter ABF.00.250.CTA. An optional cable with the appropriate LEMO connector at one end and BNC connector at the other is available upon request.
- Optical input (FC connector version): compatible with standard FC/PC-connector, suitable for fiber core diameters up to 105 µm.

## Product Number Designations

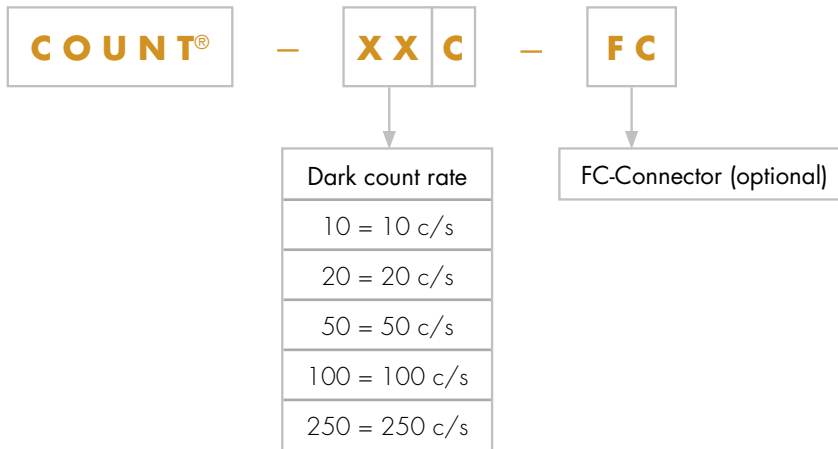

## Product Changes

LASER COMPONENTS reserves the right to make changes to the product(s) or information contained herein without notice. No liability is assumed as a result to their use or application.

## Ordering Information

Products can be ordered directly from LASER COMPONENTS or its representatives. For a complete listing of representatives, visit our website at [www.lasercomponents.com](http://www.lasercomponents.com)

Custom designed products are available on request.